

# Ambis 1-10V

## Parking LED Lighting

### Product Features

- High efficiency up to 133 lm/W
- Replacement for T8/T5 fluorescent tubes
- Homogeneous light appearance without hot spot
- Easy-click fixation technique and mounting clips for convenient installation
- Electrical installation with options for linking
- IP66 and IK10 protection rate/CE & RoHs compliant
- Reliable quality, manufacture capability, and global logistics by Delta Group 49-year establishment

### Applications



Parking



Cold Storage



Warehouse



Work Area

[www.delta-emea.com](http://www.delta-emea.com)



**DELTA**  
Smarter. Greener. Together.

	PG432IEH1L	PG445IEH1L	PG545IEH1L
Length (mm)	1200		1600
Lumen Output (lm)	4000	6000	
Input Voltage (V)	AC 220-240 V		
Power (W)	32	45	
Efficacy (lm/W)	125	133	
CRI (Ra)	> 80		
CCT (K)	4000 ± 250K (within 4 McAdam.), 3000K / 5000K / 5700K available		
Operating Temp (°C)	-20°C to 40°C		
Max. units per circuit (10A ABB MCB s200 series)	12	24	
Electrical safety class	Class II		
Protection	IP66 / IK10		
Compliance	IEC 61000-3-2 ClassC Harmonic (1-40) / THD (Total Harmonic <20% ) / CE / RoHS		
Tests	Glow wire test at 850°C / 4kV high-pot voltage insulation		
Installation	3-pole 2.5 mm <sup>2</sup> through-wiring		
Driver	1-10V		
Lifetime	>100,000 hrs L80/B10 at Ta 25°C; >50,000 hrs L90/B10 at Ta 25°C		
Warranty	5 Years		
Weight (kg)	1.3	1.7	

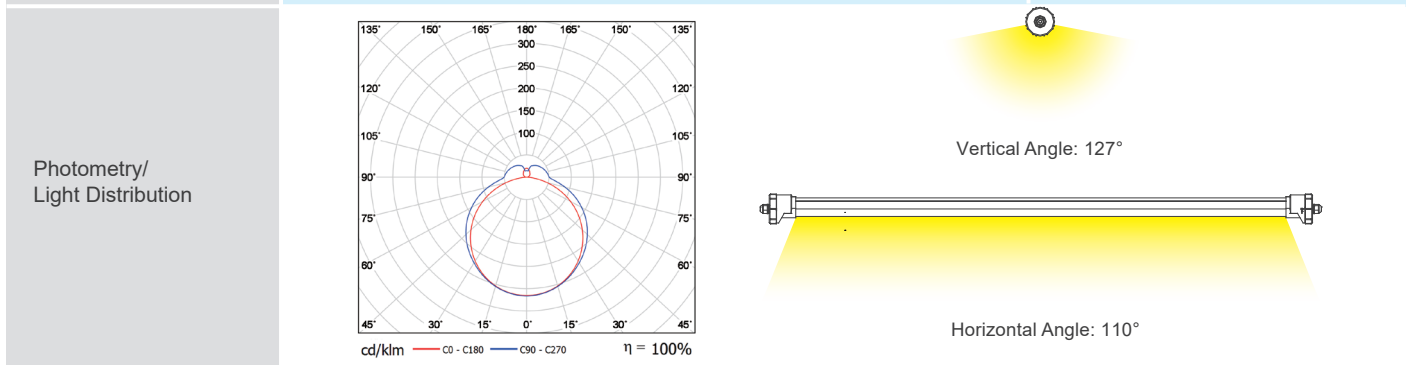

Accessories

- Sealing plug 1 pc per luminaire (for sealing the cable gland and the end luminaire in installation circuit)
- Mounting clips 2 pcs per luminaire
- Optional: Anti-vandalism SS316L mounting clips (set of 2 pcs)

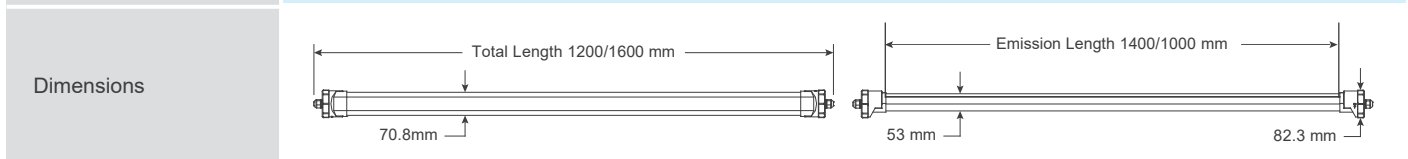

Specifications are subject to change without notice.

2020/04/15

## Delta Electronics Europe

Zandsteen 15

2132 MZ Hoofddorp, The Netherlands

TEL: +31-20-655-0900

FAX: +31-20-655-0999

For more product information and sales inquiries, please contact: [sleu@deltaww.com](mailto:sleu@deltaww.com)

[www.delta-emea.com/ledlighting](http://www.delta-emea.com/ledlighting)